

# VALVE SENSE INSPECTION

FAST AND EASY LEAK DETECTION IN VALVES

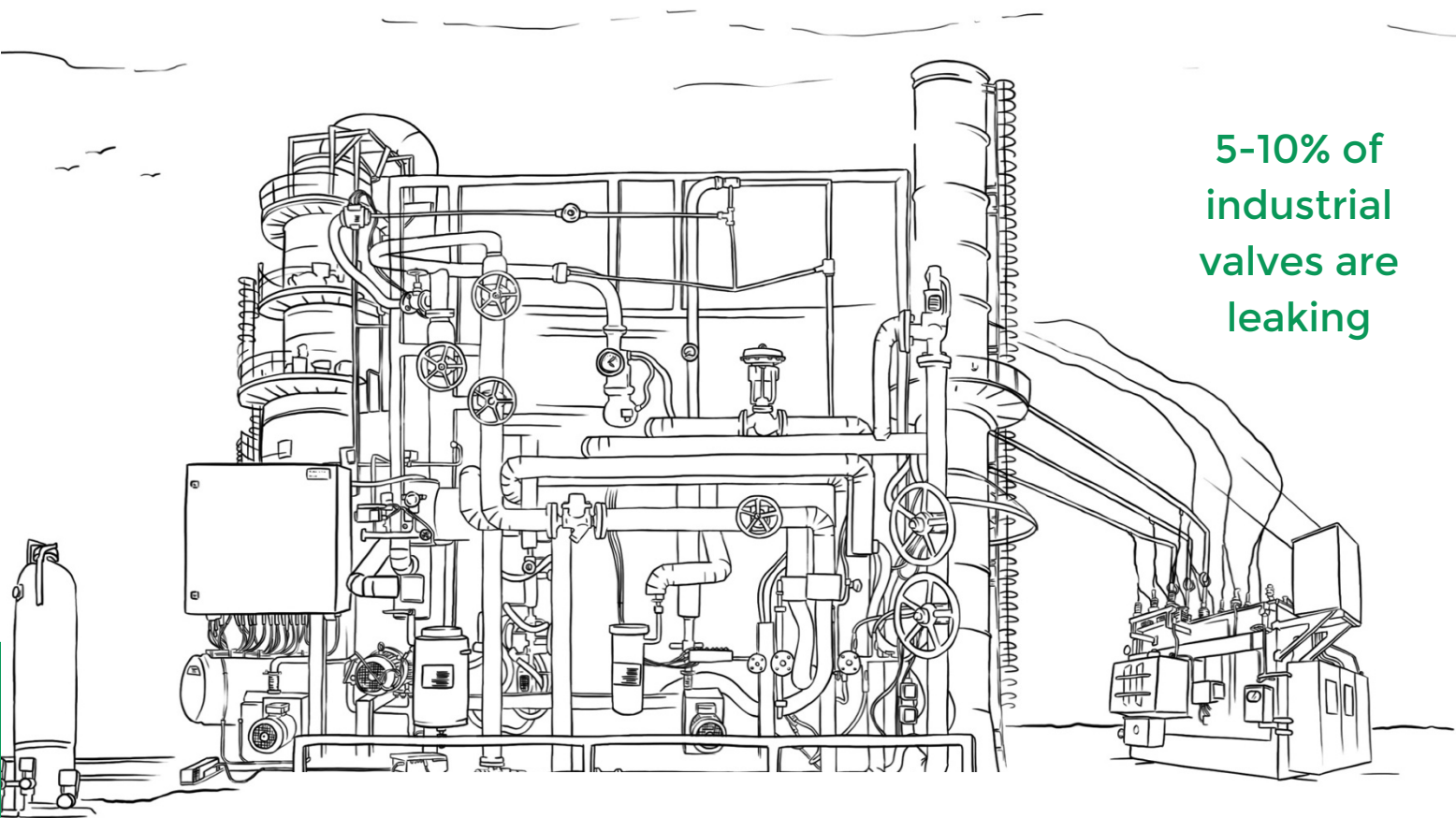



5-10% of industrial valves are leaking

**START PROTECTING YOUR ASSETS TODAY**

## THE PROBLEM

Leaking valves in industry can lead to:

- > **Losses** (energy, steam, pressurized air, scrap, product)
- > **Risk of injury**
- > **Contamination**

Currently valves are mostly removed and tested on a test bench → This is time consuming and causes downtime.

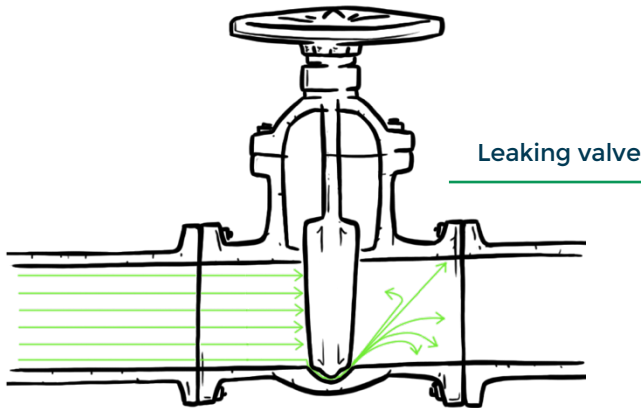

A blurred photograph of an industrial facility, likely an oil or gas refinery, featuring several tall, vertical distillation columns and a complex network of pipes and structural steel. The scene is bathed in a warm, golden light, possibly from a low sun, creating a hazy atmosphere. The background is a pale, overcast sky.

**VALVES ARE THEREFORE RARELY INSPECTED AND  
LEAKS REMAIN UNNOTICED FOR A LONG TIME**

## OUR SOLUTION

- > A smart and mobile inspection system for leak detection in valves
- > Inspect valves while process is in operation
- > Automated results immediately on site
- > All inspection data is structurally stored in a platform



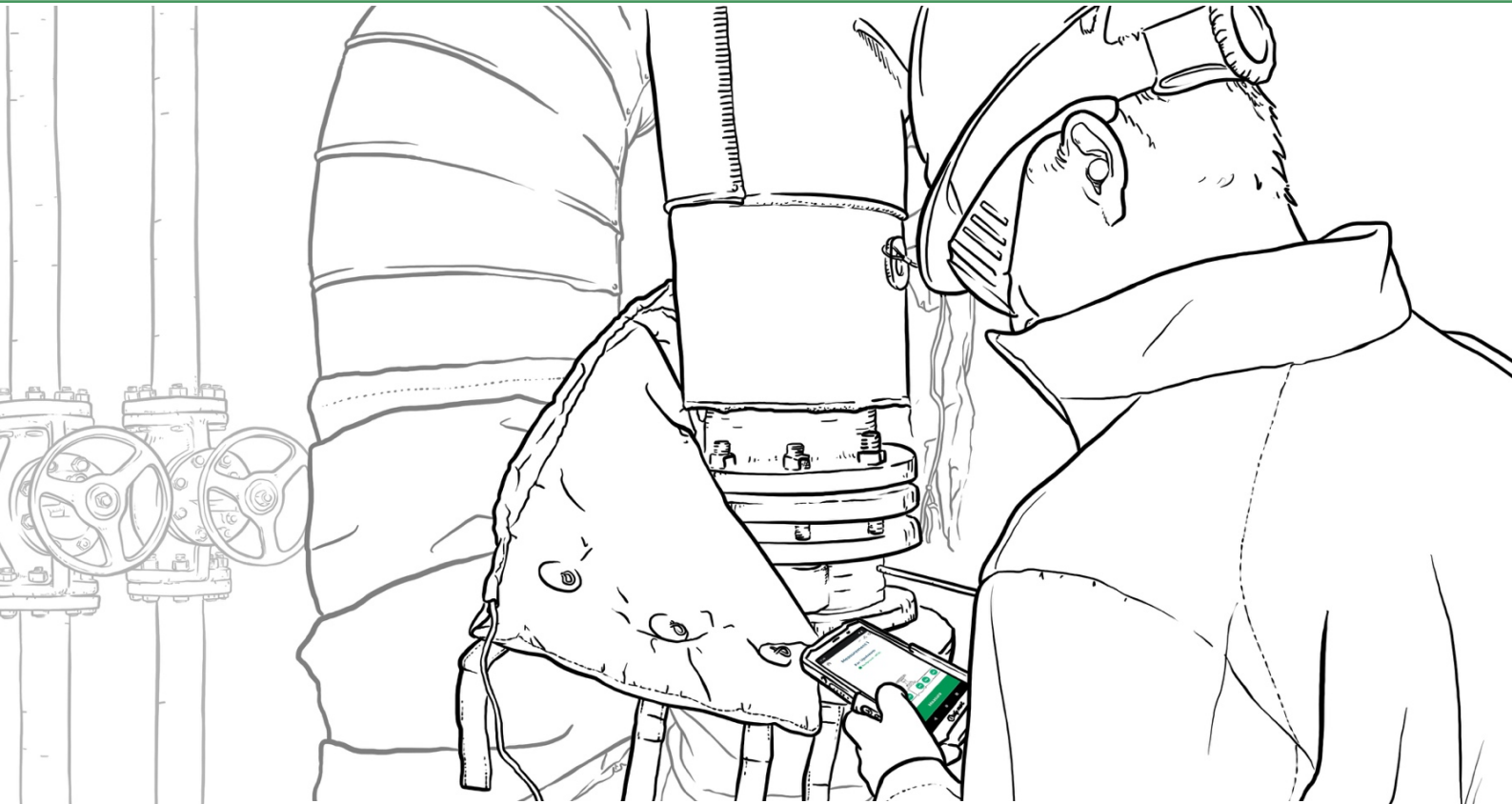

**IMPROVE EFFICIENCY AND REDUCE TIME & COSTS**

## VALVE SENSE: VALVE LEAK DETECTION IN HAZARDOUS AREAS



### Acoustic emission meets digitalization

AE sensors are connected with i.safe MOBILE's IS540.1 smartphone for Zone 1/21. Equipped with the Senseven App and supported by artificial intelligence

## No expertise required due to automatic leak detection and quantification

Software-guided inspection process with immediate results on site thanks to algorithms and AI



All data structurally stored



Software-guided inspection process

## Automatic data synchronization

All inspection data is automatically stored in our cloud platform for further analysis and easy reporting

## SENSEVEN BACKOFFICE:

Your structured web platform for all inspection data

- > Data is automatically synchronized
- > Analyze results in detail
- > Look at trends over time
- > Upload pictures
- > Add comments
- > Auto-generate reports



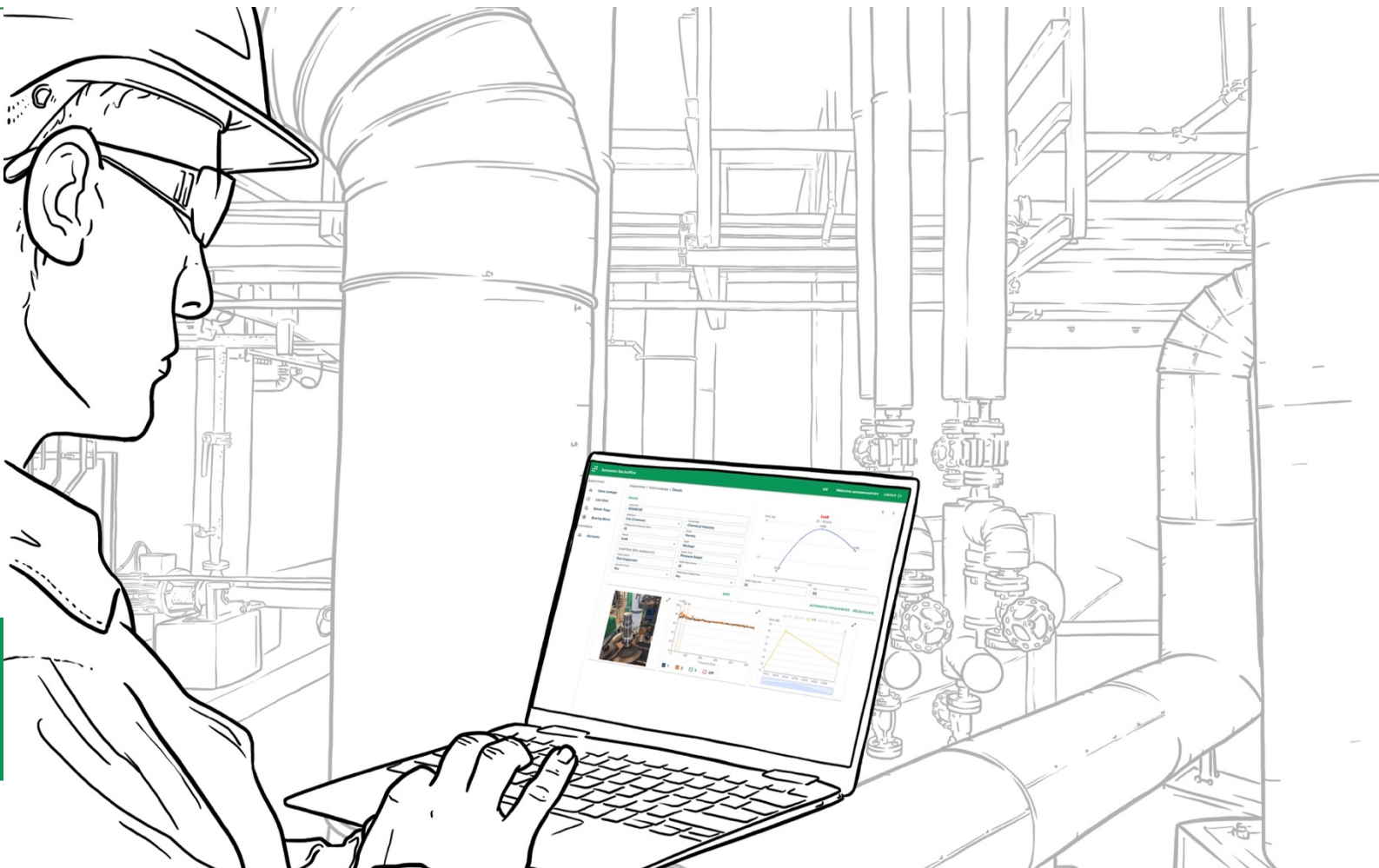

## A CASE STUDY:



### The situation:

- > Energy producer uses steam in power generation process
- > Valves need to function properly to avoid steam leakages and ensure boiler efficiency

### Inspection with Valve Sense:

- > 15 valves have been inspected
- > 1 valve which was expected to be leaking was actually tight
- > 2 leaking valves were detected
- > Estimated loss: up to EUR 30,000 / year

# ELEVATE YOUR VALVE RELIABILITY WITH VALVE SENSE

TRUSTED BY MAJOR PLAYERS



# TECHNICAL SPECIFICATIONS

## Valve Sense Approvals:



ATEX (Europe)  
approved

II 2G Ex ib IIC T4 Gb  
II 2D Ex ib IIIC T135°C Db



IECEX (International)  
approved

Ex ib IIC T4 Gb  
Ex ib IIIC T135°C Db



NEC500 (North America)  
approved

Class I Div. 1 Groups A, B, C, D, T4  
Class II Div. 1 Groups E, F, G, T135°C  
Class III Div. 1



KCs (South Korea)  
approved

Ex ib IIC T4  
Ex ib IIIC T135°C

## Measuring Electronic: Model MVS1A01



**Analog band width**

20-500kHz

**Input range**

90 dBAE / 100 dBAE

**Sampling rate**

Res.: 2 MHz / 16 bit

**Power consumption**

< 700 mW

**Dimension**

Size: 141.2 x 96.0 x 51,85 mm  
weight: 219.3 g

**Operating temperature**

Usable from -20°C to +55°C

**Sensors:  
IS-SU150F1.1 and  
IS-SU150F2.1**



<b>Frequency range</b>	100-450 kHz
<b>Operating temperature</b>	-40°C - +120°C
<b>Dimension</b>	22.3 x 18.2 mm 22.3 x 37.5 mm
<b>Weight</b>	29g 63.4g

**Cable:  
IS-SC120BB1.1**



<b>Length</b>	120 cm, 2 pcs/set
<b>Temperature range</b>	-20°C - +60°C
<b>Weight</b>	20g (each)

**Waveguide:  
IS-WGLF1.1**

<b>Diameter</b>	55mm
<b>Temperature range</b>	>120°C and < -50°C
<b>Dimension</b>	220 x 7 mm
<b>Weight</b>	89.8g



**Senseven GmbH**

Montleartstrasse 1b/7/14

1140 Vienna

Austria

Web: [www.senseven.ai](http://www.senseven.ai)

Email: [sales@senseven.ai](mailto:sales@senseven.ai)